



ICC Evaluation Service, Inc.
www.icc-es.org

Business/Regional Office ■ 5360 Workman Mill Road, Whittier, California 90601 ■ (562) 699-0543
Regional Office ■ 900 Montclair Road, Suite A, Birmingham, Alabama 35213 ■ (205) 599-9800
Regional Office ■ 4051 West Flossmoor Road, Country Club Hills, Illinois 60478 ■ (708) 799-2305

Legacy report on the 1997 Uniform Building Code™

DIVISION: 05—METALS
Section: 05090—Metal Fastenings

DIVISION: 06—WOOD AND PLASTICS
Section: 06090—Wood and Plastic Fastenings

STREAKER™ STEEL SCREWS, GRABBER DRIVALL™ SELF-DRILLING SCREWS, GRABBER™ COARSE THREAD SCREWS, GRABBER™ PLYWOOD SCREWS AND SUPERDRIVE™ SCREWS

JOHN WAGNER ASSOCIATES, INC.,
GRABBER DIVISION
205 MASON CIRCLE
CONCORD, CALIFORNIA 94520

HITACHI KOKI USA LTD.
3950 STEVE REYNOLDS BOULEVARD
NORCROSS, GEORGIA 30093-3061

1.0 SUBJECT

Streaker Steel Screws, Grabber Drivall Self-drilling Screws, Grabber Coarse Thread Screws, Grabber Plywood Screws and SuperDrive Screws.

2.0 DESCRIPTION

2.1 General:

All Grabber brand and Streaker screws are manufactured from heat-treated steel wire, conforming to ASTM A 548, Grade 1013 to 1022. All screws used in interior applications will have a coating consisting of grey or black phosphate, or white or yellow chromated zinc. Screws used in exposed exterior or corrosion environments have the Grabbergard coating.

The Streaker and Grabber screws noted in Table 5 are also supplied as Hitachi SuperDrive Screws identified as noted in Section 2.4.2.

2.1.1 Streaker Steel Screws: Streaker screws are self-piercing, self-tapping steel screws with a special hardened point that allows direct penetration of metal and are for connections to metal up to No. 20 gage in thickness. Streaker Steel screws must comply with SAE J78 and ASTM C 1002. Streaker screws are available in gage Nos. 6, 7, 8, and 10, with flat bugle, pan, hex, trim, or wafer heads. These screws

are typically used to connect light-gage, cold-formed steel members or structural elements complying with Chapter 22, Division VII, of the 1997 Uniform Building Code™ (UBC), and to connect lath-to-wood, as stated in Section 2.2.6 of this report.

2.1.2 Grabber Self-drilling Screws: Grabber self-drilling screws are self-drilling, self-tapping screws for use in connections to metal of thicknesses from 20 to 12 gage. Grabber self-drilling screws are manufactured in gage Nos. 6, 7, 8, 10, 12, and 14, with bugle, pan, hex, trim, and wafer heads. Grabber self-drilling screws must comply with SAE J78 and ASTM C 954. These screws are typically used to connect light-gage, cold-formed steel members or structural elements complying with Chapter 22, Division VII, of the UBC.

2.1.3 Grabber Coarse Thread Screws: Grabber coarse thread screws are for use in wood-to-wood connections. The screws are manufactured in gage Nos. 6, 7, 8, and 10, with flat or wafer heads. The Grabber coarse thread screws must comply with ANSI/ASME B18.6.1.

2.1.4 Grabber Plywood Screws: Grabber plywood screws are for use in wood-to-wood and plywood-to-wood connections. The screws are manufactured in No. 8 gage, with flat heads, and must comply with ANSI/ASME B18.6.1. The screws have a short threaded length near the screw head for the purpose of attachment to a self-feeding, screw-gun system, typically used to attach plywood and other rated sheathing to structural wood framing.

2.2 Connections:

2.2.1 Metal-to-metal Connections: Allowable shear and tension (pullout) values are listed in Table 1 of this report. The shear values are for a single shear connection, consisting of two sheets of the same material type and thickness. Allowable tension values are for pullout of a screw from a single sheet of steel. For the values listed, steel sheets must conform with ASTM A 653-96, SS Grade 33, with a minimum 33,000 psi (228 MPa) yield strength for steel sheet gage Nos. 25 to 18; and with ASTM A 653-96, SS Grade 50 with 50,000 psi (345 MPa) minimum yield strength for steel sheet gage Nos. 16, 14, and 12.

2.2.2 Attachment of Wood Structural Panels and Particleboard: For the attachment of wood structural panels and particleboard, the use of No. 8 Grabber plywood screws must comply with this report and Chapter 23 of the UBC. The screw length and spacing must be as shown in Tables 2 and 2A and Figure 1 of this report.

*Revised September 1, 2003

ICC-ES legacy reports are not to be construed as representing aesthetics or any other attributes not specifically addressed, nor are they to be construed as an endorsement of the subject of the report or a recommendation for its use. There is no warranty by ICC Evaluation Service, Inc., express or implied, as to any finding or other matter in this report, or as to any product covered by the report.



2.2.3 Wood Connections: Lateral design loads must be determined in accordance with Part XI of the NDS* using a bending yield strength of 187,400 psi (1292 MPa) for the No. 8 Grabber coarse thread or Grabber plywood screws. Withdrawal design loads must be in accordance with Part XI of the NDS*.

2.2.4 Wood Structural Panel Shear Connections: Use of No. 8 Grabber plywood or coarse thread screws for the attachment of structural plywood and other rated panels to structural wood framing must comply with this report and Chapter 23 of the UBC. The allowable shear values in Table 3 may be used for the design of horizontal diaphragms. The allowable shear values in Table 4 may be used for the design of shear walls.

2.2.5 Attachment of Gypsum Wallboard to Wood or Metal Framing: Attachment of gypsum wallboard to wood framing must be done with Grabber coarse thread screws. Attachment of gypsum wallboard to maximum No. 20 gage thick metal framing must be done with Streaker steel screws. Grabber self-drilling screws must be used for metal thicknesses of No. 20 gage to No. 12 gage.

2.2.6 Attachment of Lath-to-wood or Lath-to-metal Framing: Attachment of lath-to-wood framing must be done with Streaker steel screws. Attachment of lath-to-metal framing must be done with Streaker steel screws, to maximum No. 20 gage metal thickness, and with Grabber self-drilling screws for metal thicknesses of No. 20 gage to No. 12 gage. Screw length and spacing must comply with Table 25-C of the UBC. All screws used to connect lath must have wafer heads.

2.3 Installation:

Self-drilling and Streaker screw fasteners are self-tapping and installed without pre-drilling holes in the receiving pieces of the connection. Grabber self-drilling screws are recommended to be installed with a variable-speed screw gun set not to exceed 2,500 rpm. Streaker steel screws and Grabber coarse thread and plywood screws are recommended to be installed with a single- or variable-speed screw gun set not to exceed 4,000 rpm. All drills must incorporate a depth-sensitive or torque-limiting nose piece.

For metal-to-metal or connections to metal, the installed fasteners must protrude through and beyond the metal member a minimum of three full threads. The distance from the center of a fastener to the end or edge of a steel member or element must not be less than three times the screw diameter. The minimum edge and end distance for connections subjected to shear force in one direction only may be reduced to 1.5 times the screw diameter in the direction perpendicular to the force.

For wood-to-wood connections, including plywood and rated sheathing, installation of the fasteners must comply with Figure 1 of this report and Part XI of the NDS*.

2.4 Identification:

2.4.1 Grabber Screws: Fastener containers are identified by the designation "GRABBER"; description of the type of fasteners (Streaker Steel, Drivall Self-drilling, Coarse Thread,

or Plywood), and the coating and length; and the evaluation report number (ER-5280), on the packaging. The minimum bending yield strength is also included as identification on containers of No. 8 gage Grabber Coarse Thread and No. 8 gage Grabber Plywood screws. Additionally, the head of each fastener is stamped with a "G" as shown in Figure 2.

2.4.2 Hitachi Screws: Fastener containers are identified by the designation "HITACHI SUPERDRIVE"; description of the type of fasteners (Steel, Self-drilling, Coarse Thread, or Plywood), and the coating and length; and the evaluation report number (ER-5280), on the packaging. The minimum bending yield strength is also included as identification on containers of No. 8 gage Hitachi SuperDrive Coarse Thread and No. 8 gage Hitachi SuperDrive Plywood screws. Additionally, the head of each fastener is stamped with an "H" as shown in Figure 3.

3.0 EVIDENCE SUBMITTED

Calculations and test reports in accordance with the ICC-ES Interim Criteria for Tapping Screw Fasteners (AC118), dated July 1996, and the ICC-ES Interim Criteria for Wood Screws (AC120), dated September 1999.

4.0 FINDINGS

That the Streaker, Grabber and SuperDrive screws described in this report comply with the 1997 *Uniform Building Code*TM, subject to the following conditions:

- 4.1 Fasteners are installed in accordance with the manufacturer's instructions and this report.
- 4.2 Allowable loads may be increased due to duration of load, such as wind or earthquake forces, except those in Table 3 and Table 4.
- 4.3 Allowable shear and tension values for metal connections comply with Table 1.
- 4.4 Allowable shear and pullout capacities for wood connections are as determined in accordance with Part XI of the NDS*.
- 4.5 Attachment of structural panels and particleboard is in accordance with Tables 2 and 2A.
- 4.6 Use of Streaker screws for the attachment of lath-to-wood or lath-to-metal framing is in accordance with this report, and complies with Table 25-C of the code.
- 4.7 Use of Grabber Coarse Thread screws for the attachment of gypsum wallboard to wood or metal framing is in accordance with this report, and complies with Tables 25-G and 25-H of the code.
- 4.8 Allowable shear values for horizontal plywood diaphragms comply with Table 3.
- 4.9 Allowable shear values for plywood shear walls comply with Table 4.

This report is subject to re-examination in two years.

TABLE 1—METAL-TO-METAL CONNECTIONS, ALLOWABLE SCREW LOADS FOR TENSION AND SINGLE SHEAR (pounds)

		GAGE OF MATERIAL NOT IN CONTACT WITH SCREW HEAD				GAGE OF MATERIAL IN CONTACT WITH SCREW HEAD							
GAGE Thickness (inch) Thickness (mm) F _y = ksi		25 0.0188 18 33	25 0.0188 18 33	20 0.0346 33 33	20 0.0346 33 33	18 0.0451 43 33	18 0.0451 43 33	16 0.0565 54 50	16 0.0565 54 50	14 0.0713 68 50	14 0.0713 68 50	12 0.1017 97 50	12 0.1017 97 50
Allowable Loads	Nominal Screw Dia. (inch)	Shear	Tension (pullout)	Shear	Tension (pullout)	Shear	Tension (pullout)	Shear	Tension (pullout)	Shear	Tension (pullout)	Shear	Tension (pullout)
#7 Streaker	0.151	98	40	327	89	—	—	—	—	—	—	—	—
#8 Streaker	0.164	130	58	314	137	—	—	—	—	—	—	—	—
#6 Self-drill	0.138	—	—	223	95	319	115	317	—	—	—	—	—
#8 Self-drill	0.164	—	—	272	106	418	136	382	177	405	180	—	—
#10 Self-drill	0.19	—	—	271	147	429	166	533	217	558	263	664	433
#12 Self-drill	0.216	—	—	268	140	435	160	551	233	731	231	814	390
#14 Self-drill	0.250	—	—	299	96	451	184	594	224	798	241	970	386

<p>V = shear</p> <p>3 Screw Diameters</p> <p>3 full threads minimum</p> <p style="text-align: center;">Detail at shear</p>	<p>T = tension</p> <p>3 Screw Diameters</p> <p>3 full threads minimum</p> <p style="text-align: center;">Detail at tension</p>	<p>Notes:</p> <ol style="list-style-type: none"> V = Single shear capacity in pounds for two pieces of same-gage steel in close contact. T = Tension (pullout) of screw through one piece of steel. Steel sheets conform to ASTM A 653-96, Grade 33 or SS Grade 50.
---	---	--

For **SI**: 1 inch = 25.4 mm, 1 lbf = 4.45 N, 1 ksi = 6.89 MPa.

*Unless otherwise noted, for purposes of this report, NDS refers to the revised 1991 edition of, and the supplement to, the ANSI/NFoPA NDS-91 National Design Specification for Wood Construction (NDS) as adopted by reference in Division III, Part I, Chapter 23, of the UBC.

TABLE 2—ATTACHMENT OF WOOD STRUCTURAL PANELS AND PARTICLEBOARD^{1,2,3}

SUBFLOOR AND WALL SHEATHING TO FRAMING	PANEL THICKNESS	SCREW DESCRIPTION
	1/2 inch and less	No. 8 by 1 3/4-inch Grabber coarse thread or plywood screw
19/32 inch - 3/4 inch	No. 8 by 2-inch Grabber coarse thread or plywood screw	
7/8 inch - 1 inch	No. 8 by 2 1/2-inch Grabber coarse thread screw	
1 1/8 inches - 1 1/4 inches	No. 8 by 2 1/2-inch Grabber coarse thread screw	
COMBINATION SUBFLOOR—UNDERLAYMENT TO FRAMING	3/4 inch and less	No. 8 by 2-inch Grabber coarse thread or plywood screw
	7/8 inch - 1 inch	No. 8 by 2 1/2-inch Grabber coarse thread screw
	1 1/8 inches - 1 1/4 inches	No. 8 by 2 1/2-inch Grabber coarse thread screw

For **SI**: 1 inch = 25.4 mm.

¹Installation is in accordance with Figure 1 of this report and Part XI of the NDS*.

²Screws are spaced 6 inches on center at edges, and 12 inches on center at intermediate supports; where spans are 48 inches on center or more, spacing is 6 inches on center at all supports.

³Refer to Tables 3 and 4 for diaphragms and shear walls.

TABLE 2A—WOOD STRUCTURAL PANEL ROOF SHEATHING FASTENING SCHEDULE^{1,2}

WIND REGION	FASTENERS	PANEL LOCATION	ROOF FASTENING ZONE ³		
			1	2	3
			Fastening Schedule (inches on center)		
			× 25.4 for mm		
Greater than 90 mph (145 km/h)	No. 8 Grabber Plywood screws	Panel edges ⁴	6	6	4
		Panel field	6	6	6
Greater than 80 mph (129 km/h) to 90 mph (145 km/h)	No. 8 Grabber Plywood screws	Panel edges ⁴	6	6	4
		Panel field	12	6	6
80 mph (129 km/h) or less	No. 8 Grabber Plywood screws	Panel edges ⁴	6	6	6
		Panel field	12	12	12

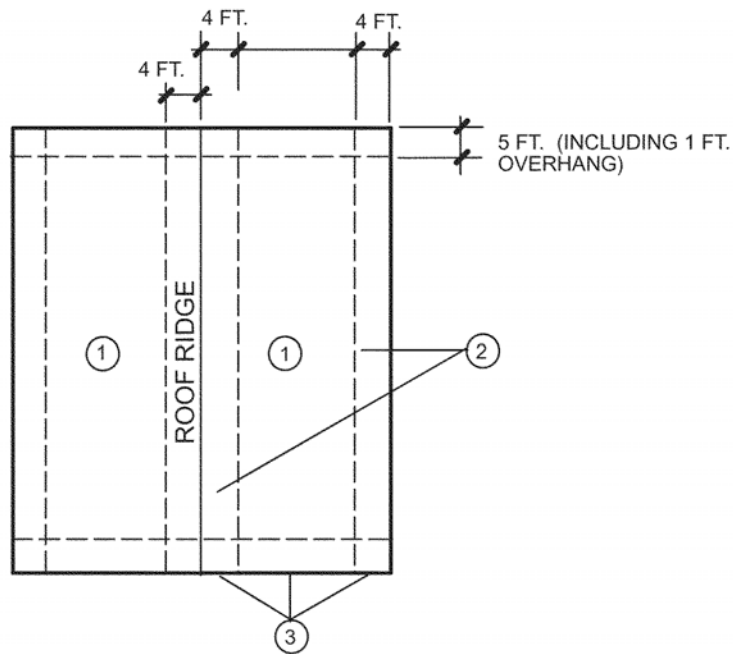

For **SI**: 1 foot = 304.8 mm.

¹Applies only to mean roof heights up to 35 feet.

²The screws must be installed in accordance with Figure 1 of this report. See Table 3 for minimum spacing at diaphragms.

³The roof fastening zones are shown above.

⁴Edge spacing also applied over roof framing at gable-end walls.

**TABLE 3—NO. 8 GAGE BY 3/4-INCH-LONG GRABBER PLYWOOD SCREWS
ALLOWABLE SHEAR IN POUNDS PER FOOT FOR HORIZONTAL WOOD STRUCTURAL PANEL
DIAPHRAGMS WITH FRAMING OF DOUGLAS FIR-LARCH OR SOUTHERN PINE¹**

PANEL GRADE	GRABBER PLYWOOD SCREW SIZE	MINIMUM SCREW PENETRATION IN FRAMING (inches)	MINIMUM NOMINAL PANEL THICKNESS (inch)	MINIMUM NOMINAL WIDTH OF FRAMING MEMBER (inches)	BLOCKED DIAPHRAGMS				UNBLOCKED DIAPHRAGMS			
					Screw spacing (in.) at diaphragm boundaries (all cases) at continuous panel edges parallel to load (Cases 3 and 4) and at all panel edges (Cases 5 and 6)				Screws spaced 6 inches (152 mm) maximum at supported edges			
					× 25.4 for mm				Case 1 (no unblocked edges or continuous joints parallel to load)		All other configurations (Cases 2, 3, 4, 5, and 6)	
					6	4	2 ^{1/2}	2 ²				
					× 25.4 for mm				× 0.0146 for N/mm			
Structural 1	No. 8 × 3/4	1 1/4	5/16	2	185	250	375	420	165	125		
				3	210	280	420	475	185	140		
			3/8	2	270	360	530	600	240	180		
			3	300	400	600	675	265	200			
			15/32	2	320	425	640	730	285	215		
				3	360	480	720	820	320	240		
C-D, C-C, sheathing, and other grades covered in UBC Standard 23-2 or 23-3	No. 8 × 3/4	1 1/4	5/16	2	170	225	335	380	150	110		
				3	190	250	380	430	170	125		
			3/8	2	240	320	480	545	215	160		
				3	270	360	540	610	240	180		
			7/16	2	255	340	505	575	230	170		
				3	285	380	570	645	255	190		
			15/32	2	290	385	575	655	255	190		
				3	325	430	650	735	290	215		

¹These values are for short-term loads due to wind or earthquake, and must be reduced 25 percent for normal loading. Space screws 12 inches on center along intermediate framing members. Allowable shear values for screws in framing members of other species set forth in Table 11A of the NDS* must be calculated for all other grades by multiplying the shear capacities for screws in Structural 1 by the following factors: 0.82 for species with a specific gravity greater than or equal to 0.42 but less than 0.49, and 0.65 for species with a specific gravity less than 0.42.

²Screws must be installed in accordance with Part XI of the NDS* and Figure 1 of this report.

**TABLE 4—NO. 8 GAGE BY 3/4-INCH-LONG GRABBER PLYWOOD SCREWS,
ALLOWABLE SHEAR FOR WIND OR SEISMIC FORCES IN POUNDS PER FOOT FOR WOOD STRUCTURAL
PANEL SHEAR WALLS WITH FRAMING OF DOUGLAS FIR-LARCH OR SOUTHERN PINE^{1,2,3,4}**

PANEL GRADE	MINIMUM NOMINAL PANEL THICKNESS (inch)	MINIMUM SCREW PENETRATION IN FRAMING (inches)	PANELS APPLIED DIRECTLY TO FRAMING			
			Screw spacing at panel edges (inches)			
			6	4	3	2 ³
			× 0.0146 for N/mm			
Structural 1	3/8	1 1/4	230 ⁴	360 ⁴	460 ⁴	610 ⁴
	7/16		255 ⁴	395 ⁴	505 ⁴	670 ⁴
	15/32		340	510	665	670
C-D, C-C, sheathing, plywood panel siding and other grades covered in UBC Standard 23-2 or 23-3	3/8	1 1/4	220 ⁴	320 ⁴	410 ⁴	530 ⁴
	7/16		240 ⁴	350 ⁴	450 ⁴	585 ⁴
	15/32		310	460	600	770

¹All panel edges backed with nominal 2-inch or wider framing. Panels installed either horizontally or vertically. Space screws at 6 inches on center along intermediate framing members for 3/8-inch-thick panel on center and 12 inches on center for other conditions and panel thicknesses. These values are for short-term loads due to wind or earthquake, and must be reduced 25 percent for normal loading. Allowable shear values for screws in framing members of other species set forth in Table 11A of the NDS* must be calculated for all other grades by multiplying the shear capacities for screws in Structural 1 by the following factors: 0.82 for species with a specific gravity greater than or equal to 0.42 but less than 0.49, and 0.65 for species with a specific gravity less than 0.42.

²Where panels are applied on both faces of a wall and screw spacing is less than 6 inches on center on either side, panel joints must be offset to fall on different framing members, or framing must be nominal 3-inch or thicker and screws on each side must be staggered.

³Framing at adjoining panel edges must be nominal 3-inch or wider, and screws must be spaced 2 inches on center.

⁴The values for 3/8-inch-thick and 7/16-inch-thick panels applied directly to framing may be increased to values shown for 15/32-inch-thick panels, provided studs are spaced a maximum of 16 inches on center, or panels are applied with long dimension across studs.

TABLE 5—STRAKER AND GRABBER SCREWS THAT ARE ALSO PROVIDED AS HITACHI SUPERDRIVE SCREWS

STRAKER/GRABBER SCREW IDENTIFICATION	HITACHI SUPERDRIVE SCREW IDENTIFICATION	DIAMETER [gage (in.)]	LENGTH (in.)
Streaker Steel	SuperDrive Steel	6 (0.138)	1 1/4, 1 5/8
Grabber Drivall Self-Drilling	SuperDrive Self-Drilling	6 (0.138)	1 1/4, 1 5/8
Grabber Coarse Thread	SuperDrive Coarse Thread	6 (0.138)	1 1/4, 1 5/8
Grabber Plywood	SuperDrive Plywood	8 (0.164)	1 1/2, 1 3/4, 2, 2 1/2, 3

For SI: 1 inch = 25.4 mm.

*Unless otherwise noted, for purposes of this report, NDS refers to the revised 1991 edition of, and the supplement to, the ANSI/NFoPA NDS-91 National Design Specification for Wood Construction (NDS) as adopted by reference in Division III, Part I, Chapter 23, of the UBC.

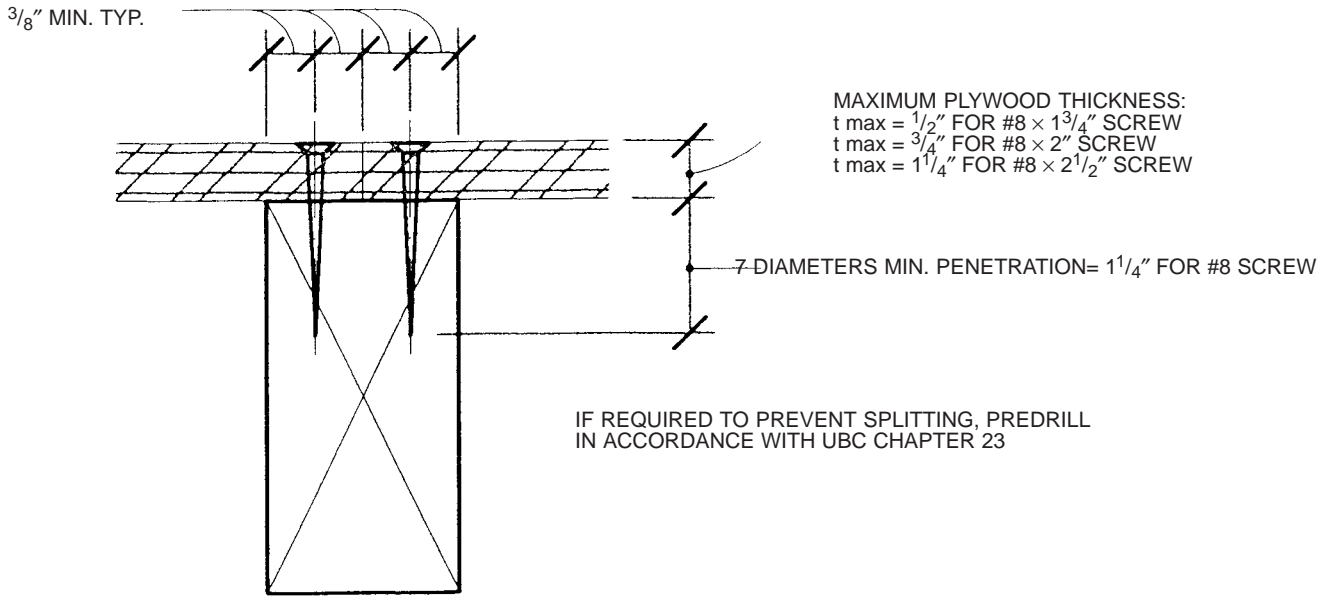

For SI: 1 inch = 25.4 mm.

FIGURE 1

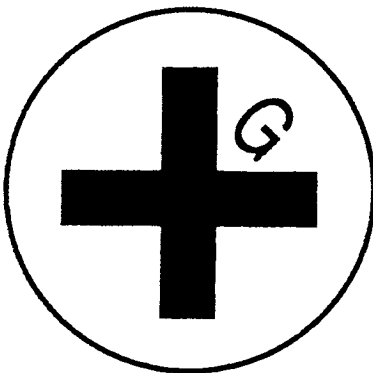
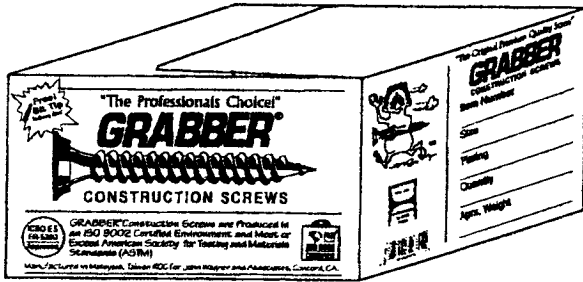

STREAKER AND GRABBER

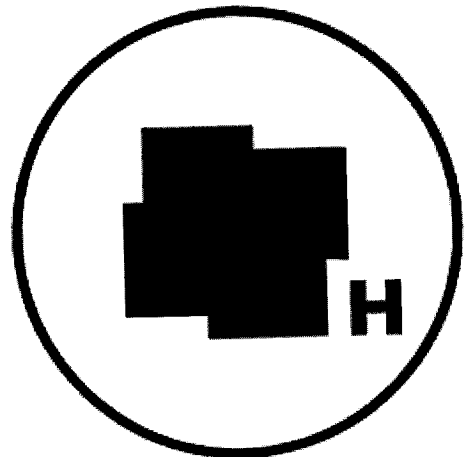

HITACHI SUPERDRIVE

FIGURE 2—TYPICAL BOX AND FASTENER HEAD STAMP IDENTIFICATION